

Extended Due Date for Submission of Quotation: 26.05.2022 upto 2.00 PM only

Due date for submission of Quotation: 10.05.2022

The Raman Research Institute invites Sealed Tenders for **Design, Development, assembly, testing and supply of FPGA SoM (ZU3EG SoC) based 2 – Channel diode laser controller housed in a 19-inch standard rack** from manufacturing consultancy firms on QCBS basis (Quality & Cost based Selection) adhering to the terms and conditions given below:

I Objective

1. Development of the carrier card for the ZU3EG SoC based SoM, with integrated Op-Amps, various ADCs, DACs and DDS with proper heat sinks with fans.
2. Development of power supply board with adequate head room compensated toroidal transformer and line filters.
3. A 7-inch touchscreen as the HMI, cable connectors and rotary knobs interfaced to the SoM via carrier card.

2 Deliverables

1. Total 2 sets of turn-key system, housing the developed SoM carrier card, all the required power supplies, front facing touchscreen, connectors, rotary knobs and three pole (On, Off, Idle) button.
2. One set to be delivered for testing before finalizing and freezing the design for the second set. Any changes required must be incorporated in the second set, without changing design topology.
3. Design documents, schematics, PCB designs and BOMs.
4. All the internal connectors and their respective cables.



3 Terms and Conditions

1. SoM will be provided by RRI, since there is a semiconductor shortage, the Bidder should select multiple alternate parts and also be flexible to adapt the design accordingly, including the change of SoM.
2. The system to be developed based on the various working prototypes already developed at RRI.
3. Various functions that are to be integrated in the carrier card must meet technical requirement of electrical noise and timing.
4. At least one year support on the system from the Bidder.
5. The sets must meet electronics scientific instrument product regulations and certifications for the following regions, European Union, Australia, New-Zealand and Indian Subcontinent.
6. First set to be delivered within four months of the release of purchase order, while the second set to be delivered with-in two months of finalizing any changes if required.

4 Technical Requirements

1. Power Supply's rail noise should be limited to 0.001% or better.
2. Ground Planes to be used in PCB designs such that there is least EMI couplings and signal distortion.
3. Timing sensitive signals and differential signals are to be properly length and impedance matched.
4. current rating of various power supplies has been specified in the block design document, (Take the current rating of LDO wherever not specified).
5. The system should be able to operate with-in 0-70° C.
6. Prototypes developed in RRI will not be provided to the Bidder, but can be accessed by the Bidder's technical team on RRI campus.
7. NDA has to be signed by the Bidder.
8. Bidder must have worked with at least one of the defence branches of Indian Government.
9. Second set can have unlimited changes for optimizations and acceptable performance as long as the topology of the design is not changed.
10. Reference design, drawing and overview of 2 Channel Laser Controller as per Annexure - I



5 Firm (Bidder) evaluation by RRI technical team

The Firm has to submit a detailed project proposal with quotations, a team at RRI will grade and select the suitable firm using 70/30 share for technical suitability and economic viability respectively (QCBS). That is, the firm will be graded for total 100 marks for awarding the work, of which 70 marks will be for technical capabilities as enumerated below and 30 marks would be for the bid quote amount.

1. 20 marks are allotted for Firm's previous experience with similar works or projects (proof to be attached with proposal).
2. 20 marks are allotted for the credentials and experience of the technical team of the Firm (CV of technical team of the firm to be attached with project proposal).
3. 30 marks are allotted for the project proposal that Firm has to submitted with quotation.
4. 30 marks are allotted for the price quoted for the proposed project.

ELIGIBILITY

1. I) As per the Government of India, Ministry of Commerce and Industry and Department for Promotion of Industry and Internal Trade (Public Procurement Section) Order No. P-45021/2/2017-PP (BE-II) dated 04 June 2020
 - a) The Bidder shall produce a certificate whether he/she belong to "Class – I' and 'Class – II supplier' and Non – Local suppliers.
 - b) Class – I' and 'Class – II supplier' and Non – Local suppliers as classified under above mentioned Order are eligible to submit the offer. While finalising the quotation, the instructions given in the above order shall prevail.
- II) As per the Government of India, Ministry of Finance and Department of Expenditure, Public Procurement Division – Office Memorandum No. F.No.6/18/2019-PPD dated 23.07.2020, the Institute reserves the right by order in writing, impose restrictions, including prior registration and/or screening, on procurement from bidders from a country or countries, or a class of countries, on grounds of defence of India, or matters directly or indirectly related thereto including national security; no procurement shall be made in violation of such restrictions.



OTHER TERMS AND CONDITIONS:

The Institute is eligible to issue Central Excise Duty Exemption Certificate or Customs Duty Concession certificate, GST Concession Certificate,

1. The quotation should include the following:
 - a) Detailed specifications, literature including Data Sheets etc. for the products quoted
 - b) Supporting Documents as per the Eligibility Criteria.
 - c) Detailed financial outlay with List of deliverables / Bill of materials / Bill of Quantities/ Unit price of items or services.
2. The quotations should be complete in all respects and the details specified in this request should be adhered to and **submitted at 2.00 PM on or before 10.05.2022. The due date for submission of quotation is extended upto 2.00 PM on or before 26.05.2022.**
3. Quotations should be valid for **180** days from the due date
4. EMD of **Rs.20,000.00** should accompany the tender enclosed with the technical bid (envelope). Payment should be by way of DD / Banker's cheque only, drawn in favour of "Raman Research Institute, Bangalore". No other form of payment will be accepted.
5. EMD of successful tenderer will be returned / adjusted on satisfactory completion of order.
6. EMD of unsuccessful tenderers will be returned within Thirty working days of opening the tender.
7. Unit price should be mentioned, which is inclusive of all applicable discounts. Taxes and other levies should be indicated separately.
8. The Institute reserves the right to modify the technical specification or the required quantity at any time but within one week before the due date and will be notified in the Institute website
9. The Institute reserves the right to reject any or all of the quotations received without assigning any reason. It also reserves the right to accept an offer other than the lowest.
10. The final order quantity can be lower or higher than that mentioned in the request.
11. The Institute reserves the right to postpone/extend the due date for submission of the quotation without assigning any reason.
12. All deliveries should be completed within the stipulated delivery time of the purchase order due date. While the Institute reserves the right not to accept delivery in part or full, beyond the due date of delivery, liquidated damages at 1% per every week of delay will be levied. Exceptions: Force Majeure.
13. Delivery of goods should be made at our stores located on campus near Mekhri Circle Bangalore – 560 080, at suppliers cost and risk.
14. The Institute reserves the right to call potential suppliers for technical discussions and product demonstrations.
15. Any Technical clarification required towards submission of offer may please be mailed to purchase@rri.res.in
16. All disputes, arbitration, if any are subject to jurisdiction of courts in Bangalore only.



CHECKLIST

TENDER TOWARDS DESIGN AND DEVELOPMENT OF FPGA BASED LASER CONTROLLER

SL. NO	CRITERIA / SPECIFICATION / CONDITION	YES / NO
1	The bidder must not be blacklisted by Central Government, State Government or any Organization in India. A certificate or undertaking to this effect must be submitted	
2	The Bidder must have worked with at least one of the defence branches of Indian Government.	
3	Quotations should be valid for 180 days from the date of opening.	
4	EMD of Rs.20,000.00 should be enclosed.	
	<p>I) As per the Government of India, Ministry of Commerce and Industry and Department for Promotion of Industry and Internal Trade (Public Procurement Section) Order No. P-45021/2/2017-PP (BE-II) dated 04 June 2020</p> <p>a) The Bidder shall produce a certificate whether he/she belong to "Class – I" and 'Class – II supplier' and Non – Local suppliers.</p> <p>b) Class – I' and 'Class – II supplier' and Non – Local suppliers as classified under above mentioned Order are eligible to submit the offer. While finalising the tender, the instructions given in the above order shall prevail.</p> <p>II) As per the Government of India, Ministry of Finance and Department of Expenditure, Public Procurement Division – Office Memorandum No. F.No.6/18/2019-PPD dated 23.07.2020, the Institute reserves the right by order in writing, impose restrictions, including prior registration and/or screening, on procurement from bidders from a country or countries, or a class of countries, on grounds of defence of India, or matters directly or indirectly related thereto including national security; no procurement shall be made in violation of such restrictions.</p>	

Signature with Seal

Note:

- 1. The bid will be opened on 27.05.2022 at 4.00 PM.**
- 2. The Bidders who have already submitted the Tender against Ref: NIT: PR – 211772 dated 13.04.2022 need not respond to this tender. The Tender submitted earlier will be considered.**



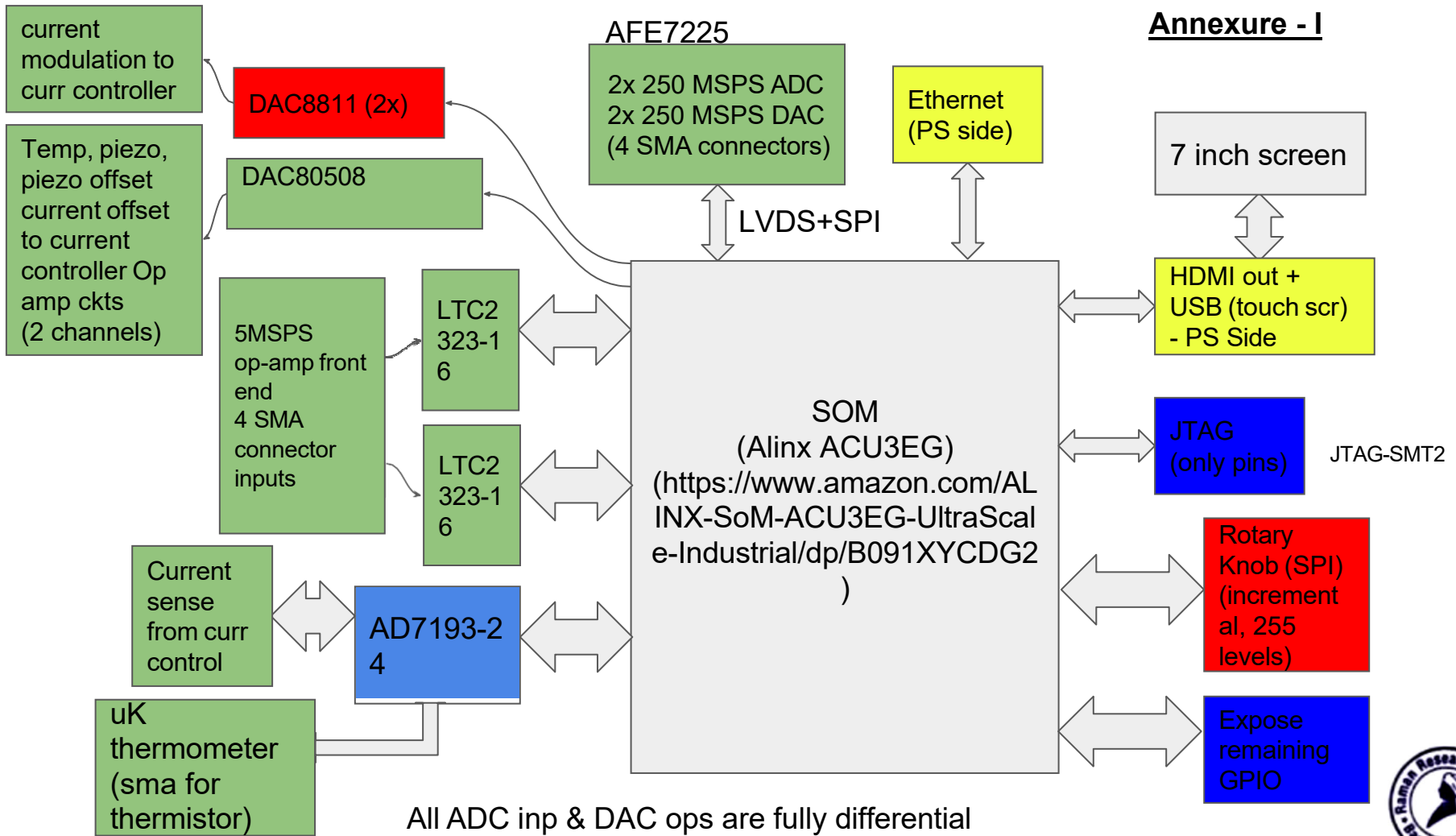

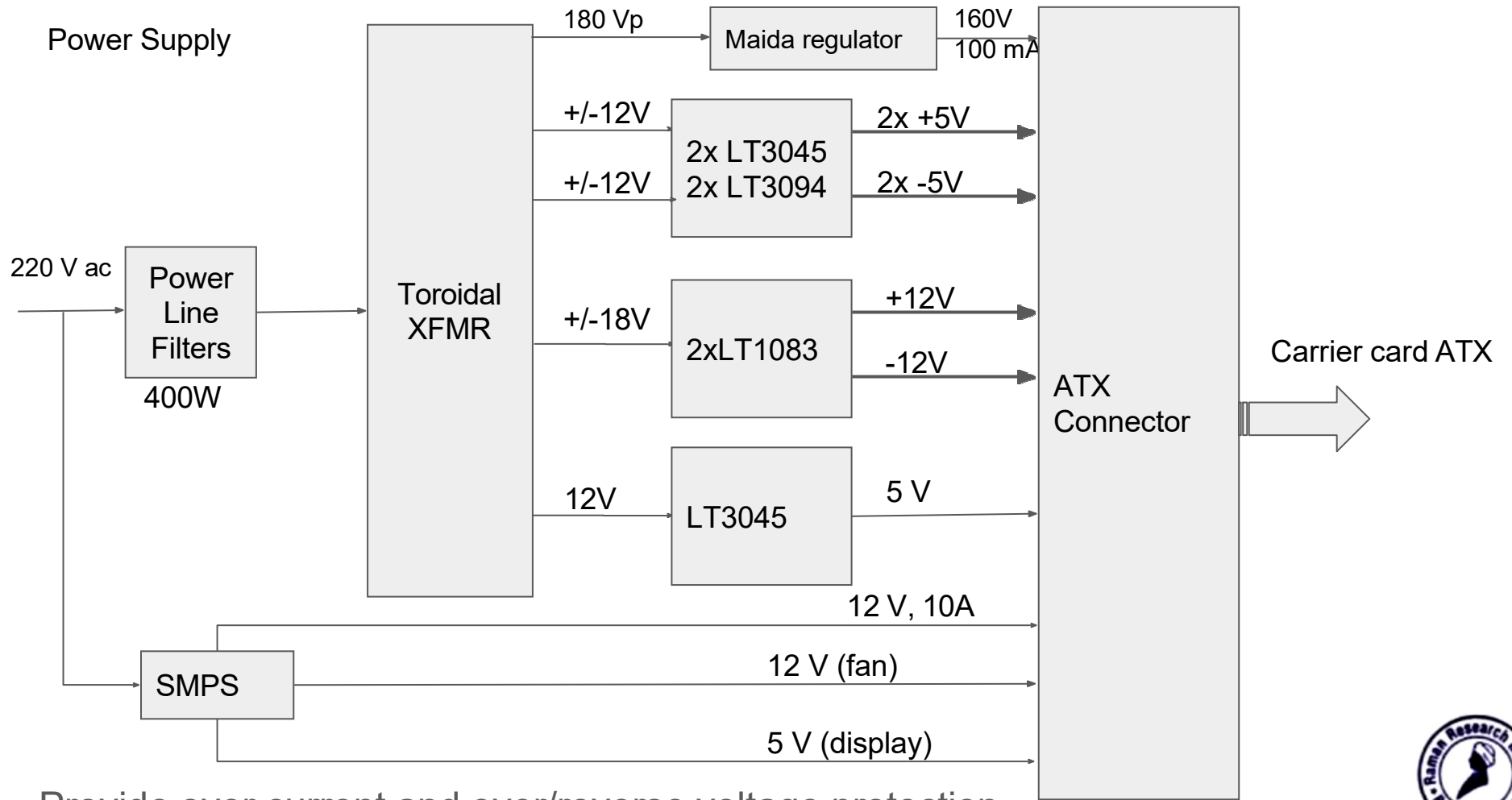

Current sensing and modulation

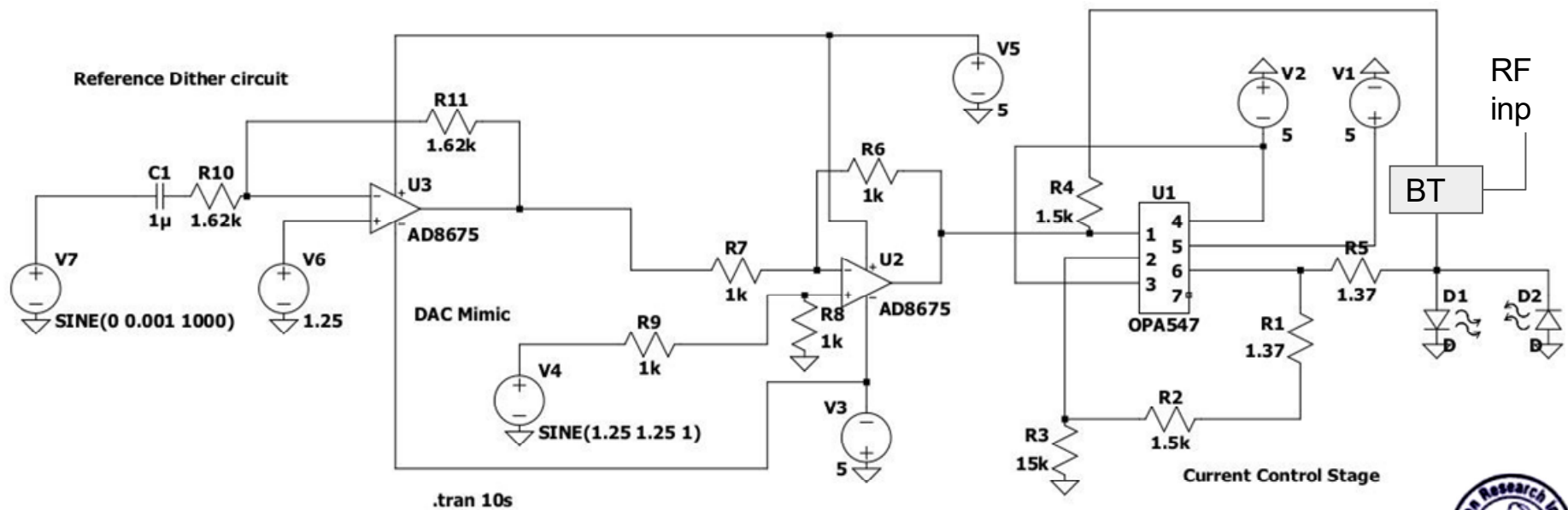

Temp sense and control

OPA549 with dual supply

V_{IN} from slow DAC
Has to be shifted in voltage such that DAC
0V output coincides with 0V

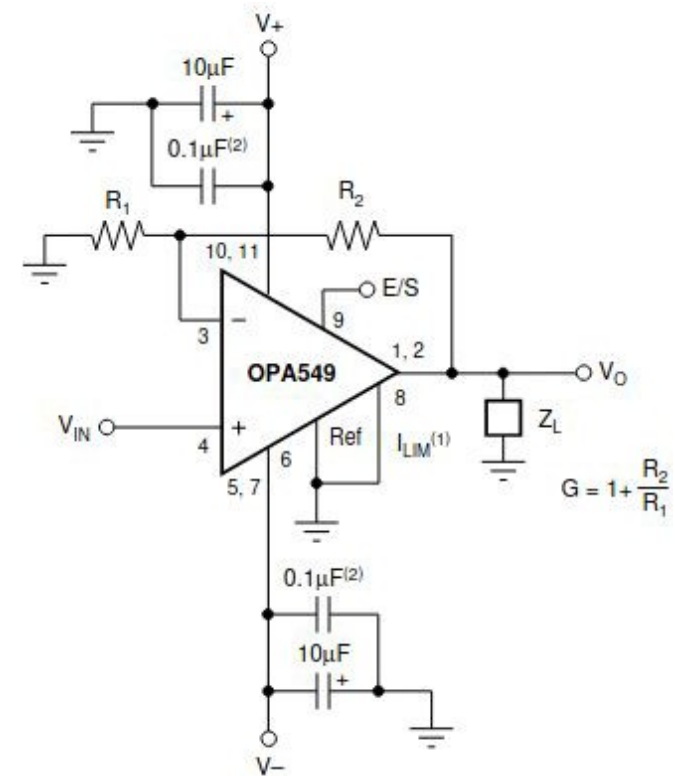

Piezo sensing and driving

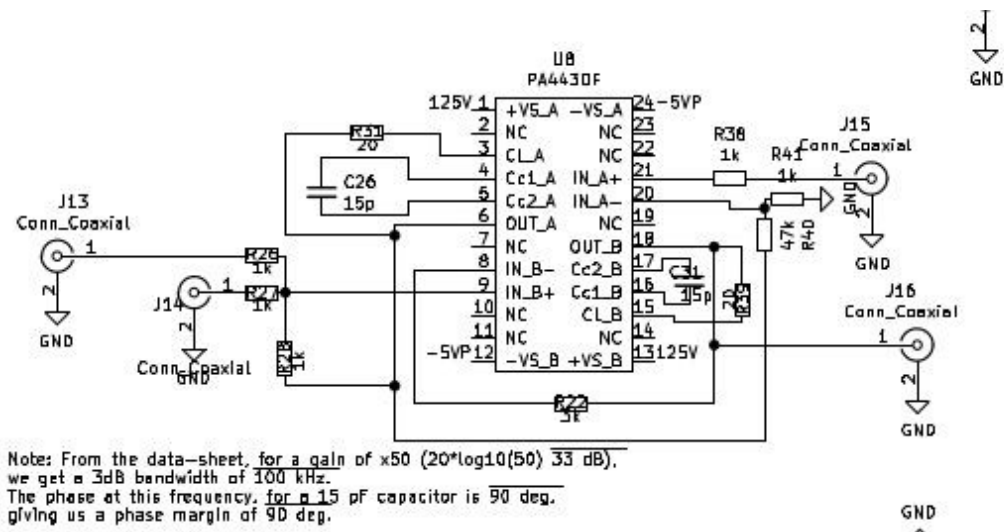

ADC Interface (per laser) - there will be 2 lasers

1. Slow ADC for Temperature (1 channel), piezo(1 channel), current(1 channel)
2. Slow DAC for temperature (1 channel), piezo (2 DAC channels per laser)
3. ADC (5 MSPS for current, 1 channel)
4. DAC (5MSPS for current, 1 channel)
5. 1x 125 MSPS ADC channel ($\frac{1}{2}$ AFE7225 Rx)
6. 1x 250 MSPS DAC channel ($\frac{1}{2}$ AFE7225 Tx)

AD9959 DDS - with output frequency - followed by a buffer, interfaced to SOM

Buffers for overvoltage protection/saturation



SOM

Add interface to all the slow ADCs and DACs

Add DDS interface (SPI, need a stable ref clock - oscc, external option)

Add high speed ADC/DAC interface (controlled impedance needed, LVDS signals)

- Daughter card

Add Ethernet, HDMI with Touch, JTAG

Route remaining GPIO to connectors

